

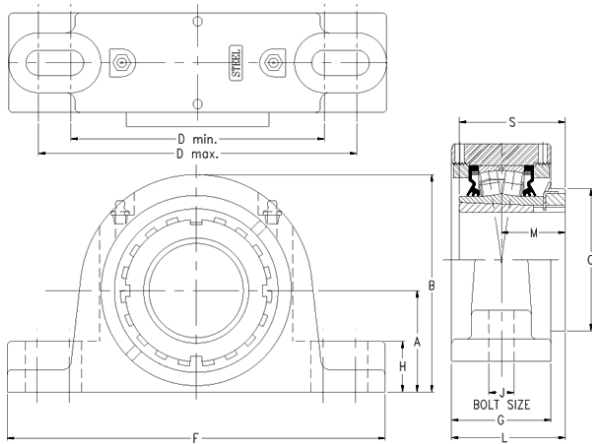

SAF BEARING LIMITED



timken TAPA15K065S Solid Block/Spherical Roller Bearing Housed Units-Tapered Adapter Two-Bolt Pillow Block

Bearing No. TAPA15K065S

Engineering Group	Mounted Bearing
Shaft Size	65 mm
Shaft Size Type	Metric
Full Timken Part Number	TAPA15K065SB
Locking Style	Tapered Adapter
Weight	27 lb
Housing Style	Two-Bolt Pillow Block
UPC Code	0883450124973
Dimension A	3.25 in
Dimension B	6.43 in
Dimension C	3.86 in
Dimension D Max	9.63 in
Dimension D Min	7.88 in
Dimension F	10.88 in
Dimension G	2.700 in
Dimension H	1.25 in
Dimension J (Bolt Size)	0.625 in
Dimension L	3.08 in
Dimension M	1.73 in
Dimension S	2.87 in
C0 - Static Load	54100 lb
C - Dynamic Load (Basic)	49900 lb
e - Geometry Factor	0.22
Y1 - Geometry Factor	3.14
Y2 - Geometry Factor	4.67

TAPA15K065S Bearing 2D drawings and 3D CAD models



SAF BEARING LIMITED

Oil Lubrication - M/N Seal	1600 rpm
Oil Lubrication - T Seal	2900 rpm
Oil Lubrication - B/C/O Seal	1300 rpm
Grease Lubrication - M/N Seal	1600 rpm
Grease Lubrication - T Seal	2400 rpm
Grease Lubrication - B/C/O Seal	1300 rpm
Float	0.083 in
Shaft Tolerance	0.0035 in
Eng Internal Radial Clearance - Min	0.0037
Eng Internal Radial Clearance - Max	0.0047
Pre Install Clearance Min	0.0037 in
Pre Install Clearance Max	0.0047 in
Int Radial Clearance Reduction Min	0.0015 in
Int Radial Clearance Reduction Max	0.0020 in
Adapter Sleeve Axial Movement Min	0.022 in
Adapter Sleeve Axial Movement Max	0.03 in
Post Install Int Radial Clearance Min	0.0017 in